



**NORTH DEVON
MOTOR CLUB**

www.ndmc.org.uk

EXMOOR TRIAL

(Est.1948)



Sunday 31st January 2010

**A ROUND OF THE 'RICHARD EGGER INSURANCE' ASWMC
CLASSIC RELIABILITY TRIALS CHAMPIONSHIP, ACTC CAR
& ACTC MOTORCYCLE 'RICHARD EGGER INSURANCE'
CLASSIC TRIAL CHAMPIONSHIPS**

**OPEN TO ALL MEMBERS OF ASWMC & ACTC MEMBER CLUBS &
ACU AFFILIATED MEMBERS.**



Photo's from previous events.

Front Cover:- Bill and Janet Bennett with that familiar grin that says it all on the 2009 event.

Rear Cover:- Al Lidgate and John Webb tackling Hunstone 2 and the Sun in 2006.

Photographs by John Barthram



EXMOOR TRIAL

Inaugural event 1948

31st January 2010

Welcome to the 2010 Exmoor Trial, which is a round of the 2010 'Richard Egger Insurance' ACTC Car and Motorcycle Classic Trial Championships, 'Richard Egger Insurance' ASWMC Classic Reliability Trial Championship.

The route is approximately 65 miles on OS Map 180 in the very north of Devon with a real mixture of sections which are non car/motorcycle breaking including the infamous Beggars Roost, High Bray and others enjoyed by competitors in previous years. The route will include stops for fuel near the start, approximately half way and near the end of the route. Due to the fact the scrutineering now takes place at a different venue than the start, we have scheduled more time between this and the start time as some entrants last year missed out on their breakfast at the Cedars.

As last year you can select how you want to receive your Final Regs, Route Instructions and Results. You can select on the entry form - via post or via e-mail in MS Word or Adobe file.

From January 2008 car passengers in National-B Trials (ie Classes 1-8) are required to be members of one of the invited clubs. If your passenger is not currently a member of one of the invited clubs, they can become a 'passenger member' of ACTC for life for a fee of £1.00.

For those who do not wish to travel on the morning of the trial can find accommodation at either the Cedars Inn (start venue), tel:01271 371784, Stag Hunters Inn (finish venue) tel:01598 741222 – from £30 B & B, or Manor Hotel (Beggars Roost), tel:01598 752404, Travellodge Barnstaple Roundswll Services, tel:0870 191 1845. If you want to book, phone them direct and mention the North Devon Motor Club's trial.

We hope you will enter this event and find the day both interesting and challenging, we are working hard to make it as competitive as possible.

ACKNOWLEDGEMENTS

The North Devon Motor Club would like to extend their thanks to the following for their assistance provided in the promotion of the 2010 North Devon Exmoor Trial.

MOTOR SPORTS ASSOCIATION LTD	AUTO-CYCLE UNION Ltd.
NORTH DEVON DISTRICT COUNCIL	EXMOOR NATIONAL PARK
DEVON AND CORNWALL CONSTABULARY	ROGERS SERVICE STN
THE PROPRIETORS OF THE CEDARS INN	ROUNDSWELL SERVICE
STN THE PROPRIETORS OF THE STAG HUNTERS INN	BARBROOK SERVICE
STN IRELANDS MOTOR SERVICES	KIRKHAM TYRE
SERVICE ALL MARSHALS, PR CREWS & ALL OWNERS AND DRIVERS OF RECOVERY VEHICLES, ALL PARISHES AND OWNERS OF PRIVATE LAND AND RESIDENTS THROUGH WHICH THE ROUTE PASSES	

NORTH DEVON MOTOR CLUB
EXMOOR TRIAL

SUPPLEMENTARY REGULATIONS

1. The North Devon Motor Club will organise a National 'B' Permit (Cars)/ Regional Restricted Permit (Motorcycles) Classic Reliability Trial on 31st January 2010, starting at the Cedars Lodge Inn, Bickington, Barnstaple (MR 180/539325).
2. The meeting will be governed by the General Regulations of the Motor Sports Association Ltd (incorporating the provisions of the International Sporting Code of the FIA), the General Regulations of the ACU, these Supplementary Regulations and any written instructions that the organising club may issue for the event.
3. MSA Permit No.*****, ACU Permit number ACU*****, DOE Authorisation number 26185JA31 has been issued.
4. The event is open to Cars: all fully elected members of the organising club and members of member clubs of the ASWMC and ACTC, Motorcycles: all affiliated members of the ACU Ltd (see ACU AFFILIATION MEMBERSHIP).
5. The event is a round of the 2010 Richard Egger Insurance ACTC (cars & motorcycle) and the 2010 Richard Egger Insurance ASWMC Classic Reliability Trials Championships (MSA Regional Championship Permit No. 16/2010).
6. All drivers must produce a valid MSA Competition Licence (car drivers only), ACU Trials Licence (motorcycle riders only). All drivers and **passengers** must produce Club Membership Card, Championship Registration Card (where applicable) for inspection at signing on. Car drivers must produce current MOT Certificate for inspection at 'scrutineering'.
7. The programme of the meeting will be:
Scrutineering starts at 7.30am, individual times for scrutineering will be notified in the Final Instructions. Any competitor not signed-on 15 minutes before his/her start time may be excluded. First competitor starts at 8.46am.
8. Public roads will be used to link sections. There will be at least 12 sections/tests on public/private land. Details of the sections/tests will be issued before the event. The route will be approximately 65 miles on OS map 180.
9. The event will consist of fifteen classes as follows:
 - (A) Solo motorcycles of British manufacture. (Engine & Frame)(Pre 65)
 - (B1) Solo motorcycles up to 225cc
 - (B2) Solo motorcycles over 225cc and up to 450cc.
 - (C) Solo motorcycles over 450cc.
 - (D) Motorcycles with touring or trials sidecars.
 - (E) 3 Wheelers (SEE APPENDIX)
 - (1) Front engine, front wheel drive Production cars (except vehicles in Class 6).
 - (2) Production cars manufactured prior to 1941. and the following:- MG TC, Morgan 4-4 Series 1, HRG 1100 & 1500, and Ford models (upright models to 1959) E04A, E494A, E4930A/B, and 103E.
 - (3) Front engine rear wheel drive Production saloons (except vehicles in Class 6).



NORTH DEVON MOTOR CLUB
MEMBERSHIP APPLICATION FORM

Please complete in BLOCK CAPITALS and return with the full remittance to:
Sarah Knight Close Court Eddys Lane Barnstaple Devon EX32 9BJ.

APPLICANT'S NAME.....

ADDITIONAL NAME(S).....

ADDRESS.....

POST CODE..... TEL. No.....

E-mail Mobile.....

FEES: Full member	(£18.00)	£
Additional member(s)†	(£5.00 per person)	£
Junior member (under 17)	(£5.00 per person)	£
Competition member	(£10.00 per person)	£
I/We* enclose CHEQUE/PO/CASH* to the value of		£
(Cheques to be made payable to NORTH DEVON MOTOR CLUB)		

I/We* hereby apply for membership of the North Devon Motor Club and hereby agree to abide by the rules of the Club.

SIGNATURE(S).....

DATE.....

† Any Additional Members **must** be resident at the same address as Full member.

*Delete as appropriate

Fees for applications made after 30 June will be subject to a 50% reduction. All memberships shall cease on 31st December each year. Names and addresses will be stored on a single computer for the sole purpose of NDMC mailings to members. By their nature, email addresses may be more widely circulated.

For official use only:	Membership No.
------------------------	----------------

PERMITTED MOTORCYCLE TYRES

Only tyres which conform to the specification of the ACU may be used.

ACU Dimensions.

All tyres will be measured mounted on the rim inflated to a pressure of 14lbs/sq.in and must have a nominal aspect ratio of 100/100.

Overall width (O) measured at wheel spindle height must not exceed 115mm.

Refer to diagram:-Tread depth (A) must not exceed 13mm. All tread blocks in the same circumference must be of the same depth. The space between the tread blocks (B) must not exceed 9.5mm across the tyre or 13mm in a circumferential direction (C). The space between the shoulder blocks (D) must not exceed 22mm. The space across the tread (E) must not extend completely across the tyre measured at right angles to the tyre wall unless broken by a block. All main tread blocks must in principle be parallel with or at right angles in the tyre axis. (Tyre must have the same appearance if reversed and conform in principle with these diagrams). The tyre surface must not be fitted with any subsequently mounted elements such as anti-skid devices, chains, etc.

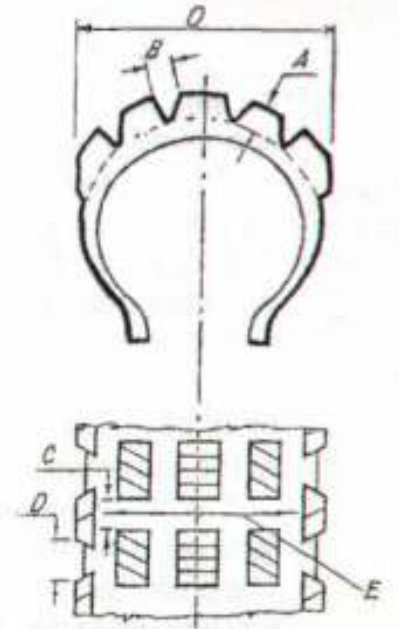

These dimensions will apply irrespective of Machine manufacturers or Tyre manufacturers statements.

Trials tyres for this event must be road legal.

NDMC Dimensions.

In addition to above specifications the North

Devon Motor Club will accept tyres which have

a non-square/rectangular block. However, the space between the blocks across the tread must

not exceed 12mm, and not exceed 16mm when

measured in a circumferential direction. The

space across the tread must not extend

completely across the tyre measured at right

angles to the tyre wall unless broken by a block

An example of an acceptable tyre = Bridgestone Trailwing 302.

Trials tyres for this event must be road legal.

- (4) Rear engine rear wheel drive Production saloons up to and including 1300cc (except vehicles in Class 7).
- (5) Front engine Production sports cars (except vehicles in class 1 and 6). Vehicles built from pre-1941 components (except vehicles in Class 2) and satisfying the tyre regulations stated in 6.7.5.
- (6) Rear engine rear wheel drive Production cars (except vehicles in Class 4. Front engine Production cars fitted with torque biasing differentials as original equipment.
- (7) Production cars modified beyond permitted limits. Rear engine Production cars fitted with torque biasing differentials as standard equipment. Front engine cars manufactured on a limited basis conforming to accepted specification. These cars comply with either or both of (i) and/or (ii) below:
 - (i) have the rearmost part of the front seat cushion(s) forward of any part of the rear tyres.
 - (ii) have a wheelbase of 90in (228.6cm) or greater.
- (8) Non-Production cars.
 - Rear engine cars (except vehicles in Classes 4, 6 & 7)
 - Front engine cars manufactured on a limited basis (except those in Class 7) including those which:-
 - (i) have the rearmost part of the front seat cushion(s) rearward of any part of the rear tyres, or
 - (ii) have a wheelbase less than 90in (228.6cm)

- 10 Awards will be presented as follows:
- *The 'Frank Harris Trophy' plus Award to the best overall CAR performance.
 - *The 'Aycliffe Press Trophy' plus Award to the best overall MOTORCYCLE performance.
 - *The 'Rodney Murch Shield' plus Award for best overall performance by a class 'D' rider.
 - *The 'Sheila Norman Shield' plus Award for best overall performance by a class 'D' passenger.
 - *The 'Barthram Classic Shield' plus Award to the best CAR performance by a North Devon Motor Club member.
 - *The 'Guy Winsor Trophy' plus Award to the best overall MOTORCYCLE performance by a North Devon Motor Club member
 - *The 'Aycliffe Press Shield' plus Award to the best overall performance for a car Bouncer/Navigator.
- Class Awards to the winner of each Class Except for the overall car & motorcycle winner. . . First Class Award subject to 5 starters in class. Second Class Award subject to 8 starters in class. Third Class Award subject to 12 starters in class. Novice Award subject to 3 Novice starters.
- *Named Trophies/Shields are the property of the North Devon Motor Club and will be presented at the Club's Annual Dinner and Awards Presentation in February 2011. These must be returned to the Club within 10 months or sooner if requested.

- 11 The entry list opens on the publication of these SR's and closes finally on 23rd January 2010. The entry fees are:
Cars £23.00, Solo Motorcycles £20.00, Combinations/3 Wheelers £21.00. All entries must be made on the Official Entry Form and accompanied by the full appropriate fee.

12. The Entry Secretary to whom all entries must be sent is

Mrs J Hayward
20 Hillcrest Road
Rumsam
Barnstaple
EX32 9EP
Tel: 07814387343.
E-mail: jillyj@hotmail.co.uk

13. The maximum entry for the meeting, including reserves, is 130 initially split as 70 cars and 60 motorcycles. Should either of these categories be under-subscribed the balance may be made up from the other. The minimum entry is 15, the minimum for each class is 2. Should any of the above figures not be reached the organisers reserve the right to cancel the meeting or amalgamate classes as necessary. Entries will be selected in reverse order of receipt. Entries may be refunded less £2.00 administration fee if cancelled in writing before the closing date above.

14. Provisional results will be displayed at the 'finish' of the event and by despatching a copy in writing via e-mail or post within 7 days of the event.

15. Any protests must be lodged in accordance with MSA/ACU General Regulations.

16. Starting numbers will be issued at the start and must be removed at the finish or upon retirement.

17. Competitors will be identified by numbers that will be provided by the organisers

18 Officials:

Club Stewards	Peter Horne., TBA
Clerk of the Course	Rodney Murch
Asst. Clerk of the Course	John Barthram
Secretary of the Meeting	Jill Hayward (07814 387343.)
Scrutineer	TBA
Chief Marshal	Eric Stanley (Tel: 01769 572877)
Results	Steve Parker
Back Marker	Nick Webber.
Child Protection Officer	Russ Drayton (Tel: 01271 812205)

19. Marking and Penalties will be as stated:
in the MSA Regulations J51 except i, k and l which are deleted.
in the ACU Regulations except the Penalties which will be explained in the Final Instructions.
There are no time penalties for this event. Some hills will be divided into sections, some may also have Stop and Re-start tests. These will be notified within the route instructions. In the event of a tie, aggregate times on the Special Tests will decide, if a tie still exists the competitor with the smaller engine cc will be held to be the winner. If a tie still exists, the time on Special Test 1 will decide.

20. All other General Regulations of the MSA Ltd. and ACU Ltd. apply as written.

21. (a) Refreshments will be available at the start. The finish will be at the 'Staghunters Inn', Brendon where competitors will sign off to collect their Finisher's Certificate. Meals will be available at the finish.

(b) Petrol will be available NEAR the start, finish and on route.

- (c) All cars must have a towing rope/eye firmly fitted.
- (d) Any competitor overtaken by the back-marker will be deemed to have retired.
- (e) Any competitor involved in an accident must make a written report to the Secretary of the Meeting at the finish (or within in 7 days if a non-finisher).
- (f) Exclude any car or competitor whose appearance, condition or performance is not of a standard appropriate to the event
- (g) All car competitors must carry a fire extinguisher to MSA specifications.
- (h) Route Cards and Section/Tests instructions will be sent by post or via e-mail during the week prior to the event.
- (i) Tyres must comply with MSA/ACU Regulations and additional NDMC regulations (see page 6), there may be a tyre pressure limit for this event.
- (j) Order of starting will be Class D, Solo Motorcycles, Class E, 8, 7, 6 followed by the remaining competitors who will run in class order. Competitors must, as far as possible, remain in numerical order throughout the event.
- (k) All vehicles must be taxed, MOT'd and insured for this event. **All Motorcycle's must be fitted with road legal lights**

(j) Competitors are not allowed to view the Sections in advance. Failure to observe this rule will incur 6 penalty points for each offence.

22. **BRIT INSURANCE – ACU/MSA ROAD TRAFFIC ACT INSURANCE SCHEME**

In order that competitors whose vehicles are not otherwise covered may obtain insurance at the event. The Club has applied to Brit Insurance Motor Sports Risk Service for a Blanket Cover note under the above scheme. This will provide competitors who need to use the scheme with **third party cover to meet the minimal Road Traffic Act requirements for the road sections of the event.**

ELIGIBILITY

To be eligible to sign-on to this cover at the event competitors must comply with all the following requirements:-

- **Be over 21 years of age and have held an appropriate full licence for at least 6 months.**
- **Have had not more than one fault accident in the last three years.**
- **Have no more than six speeding points on a licence.**
- **Have no physical or mental disabilities.**
- **No other material facts.**

Any competitor unable to comply with the above requirements may still apply for cover by completing the Third Party Road Risks Declaration Form, which can be obtained from the Secretary of the Meeting and must be mailed or faxed to Brit Insurance in **sufficient time** for a Letter of Acceptance to be issued.

All competitors wishing to benefit from the above scheme at this event **MUST** sign the Brit Insurance – Road Traffic Act Insurance Scheme signing-on form at the event. For premiums, see Entry Form.

APPENDIX

THREE-WHEELERS must comply with the following requirements:-

- a) Seating must be side by side. Passengers must remain seated.
- b) Must have a floor of metal or other substantial materials, and be surrounded by body sides to a minimum height of 12" (30cms) above the uncompressed seat cushion.
- c) The drive may be shaft or chain, driving one rear wheel only, or two front wheels via a differential which is not a torque biasing device.
- d) Engine capacity is limited up to 1300cc.